



GT Ice Maker Models

Installation and Operation Instructions

CHECK FOR FREIGHT DAMAGE BEFORE PROCEEDING: Even though damage to the carton may not be evident, check for hidden damage and if found contact the freight carrier immediately to file a claim.

THIS EQUIPMENT MUST BE INSTALLED IN COMPLIANCE WITH ALL APPLICABLE FEDERAL, STATE/PROVINCE, AND/OR LOCAL PLUMBING, ELECTRICAL, AND HEALTH/SANITATION CODES AND REQUIREMENTS.

Failure to understand and follow these instructions could lead to the following Risks and Damage

CAUTION:

- ◆ RISK OF PERSONAL INJURY, PROPERTY DAMAGE, EQUIPMENT FAILURE, OR FIRE.
- ◆ Refer all maintenance to qualified personnel.
- ◆ Never operate this equipment with covers, panels, or other parts removed or not properly secured.
- ◆ Warn all users to clean up all spills immediately, keep storage bin doors closed, and report any leaks or unusual sounds to responsible maintenance personnel.
- ◆ Use suitable lifting techniques and watch for sharp edges.
- ◆ Failure to follow all installation specifications and instructions may cause: improper operation and equipment damage or fire.

Installation Specifications

Ampacity: Minimum ampacity does not indicate typical running current value. Refer to equipment NAME PLATE data. Use minimum ampacity value for sizing branch circuit conductors up to 25 feet length. For conductor length over 25 feet up to 100 feet, increase 1 AWG size. Over 100 feet requires 2 or more AWG size increase.

Branch circuit protection: Proper protection must be provided by either fuse(s) or HACR type circuit breaker(s). Each cuber must be provided with a separately protected circuit with no other load(s). A fused disconnect installed adjacent to each ice maker is recommended, and may be required by local codes. NORMAL protector size is based on rated voltage and operation at lower than extreme temperature limits. When branch circuit conductors are sized to permit, increasing the protector size (up to the specified maximum) may avoid nuisance protector opening under harsh operating conditions.

Water supply: Minimum 20 psig supply pressure while the ice maker is filling is required. Maximum supply pressure is 100 psig. The water fill flow rate is 0.6 GRM for each GT3XX and 1 GPM for each GT5XX machine. Backflow prevention is provided by an internal air gap (accepted by NSF). If additional protection is required by local codes, any device(s) and installation of the same, including specification and cost, are the responsibility of the installation specifier.

Ice maker drain: The size of the gravity drain for the ice maker rinse and purge water must not be reduced. Individual drains from stacked ice makers may be discharged into a standpipe or manifold with a minimum 1-1/2 inch air gap at each ice maker connection.

Liquid condenser coolant pressure drop: Condenser coolant pressure drop may reach 20 psig during peak load with 85°F. coolant temperature at recommended refrigerant high-side pressure. The condenser coolant (water) regulating valve may require adjustment due to variations in the coolant supply characteristics to provide optimum efficiency.

All models are intended FOR INDOOR USE ONLY with PERMANENT CONNECTION TO THE FIELD ELECTRICAL SUPPLY.

Note for GT5XX Series Only:

Remote air-cooled condensers supplied by KOLD-DRAFT may be installed outdoors, and they require a separate electrical supply.

Other operating condition requirements:

Ice maker ambient air temperature: MINIMUM 45°F.; MAXIMUM 90°F.

Remote condenser ambient air temperature: CONSULT SERVICE MANUAL

*Ice maker ambient temperatures less than 50°F may cause erratic bin thermostat operation.

Potable water and condenser liquid supply:

Temperature: MINIMUM 45°F.; MAXIMUM 90°F.

Pressure: MINIMUM 20 psig; MAXIMUM 100 psig**

*Potable water temperatures less than 50°F are likely to cause cold-water thermostat operation (see SERVICE MANUAL).

**If regulator is used, recommended setting is 30 to 50 psig.

INSTALLATION

NOTE: For Stacked GT3XX installations, refer to the specific stacking instructions before proceeding. GT5XX ice maker cannot be stacked.

Location:

1. Position the ice storage bin with the following minimum clearances around the ice maker for ventilation and utility connections:

	GT3XX Ice Makers	GT5XX Ice Makers
REAR :	6 inches	8 inches
RIGHT SIDE:	6 inches	4 inches
LEFT SIDE:	6 inches	4 inches
TOP:	6 inches	8 inches

Level Equipment:

2. Level the bin with adjustable legs, or by shimming if the bin is to be sealed to the floor. If gaps due to shims are greater than 1/8 inch, install a cove molding around the bin bottom. Seal the bin or molding to the floor with NSF Certified RTV silicon sealant (Dow-Corning RTV 732 or equal).

Cabinet Panel, Ice Chute and Drain Pan Removal:

3. Remove the cabinet panels as follows:
 - TOP: GT3XX, Lift the front edge and pull forward until the rear clip is disengaged from the chassis.
GT5XX, lift the front edge and push backward until the rear catch is disengaged.
 - FRONT: Remove the (4) screws at the bottom and front-sides, pull forward.
 - SIDES : Pull forward and lift to disengage the clips from the chassis.
4. Remove the, ice chute and drain pan. Peel off the protective film from the ice maker and the bin exterior panels.

Gasket the Bin Top:

5. Install gasketing on top of bin. Gasket material must be positioned so that it extends to all the outside edges of the ice maker chassis.

Position the Ice Maker on the Bin Top:

6. *CAREFULLY* place the ice maker onto the bin, note the alignment of the mounting holes in the ice maker if mounting means (holes) are provided on the bin. 1/4"-20 capscrews are provided for securing the ice maker to bin. Consult the ice bin installation instructions for additional information.

Install the Ice Chute and Drain Pan:

7. Install the ice chute / drain pan. On the GT3XX installations, route the drain tube assembly through the rear of the bin and clamp the tubing to the drain pan nipple.

NOTE:

To avoid the RISK OF CONTAMINATION OF ICE IN THE BIN, provide separate, unconnected, drains for the ice maker and the bin. Consult local codes for suitable connections to the building drains.

Water Supply:

8. Purge the potable water supply line.

Remove Shipping Strap:

9. Remove the water plate shipping strap.



Install Thermostat:

10. **GT3XX:** Install the insulated bin thermostat tube through the grommet, in the right side wall of the frame, along the wall through the grommet in the drain pan support. Push the tube down as far as it will go. Be careful not to kink the Thermostat tube when bending it. Form it against your finger or other round object.

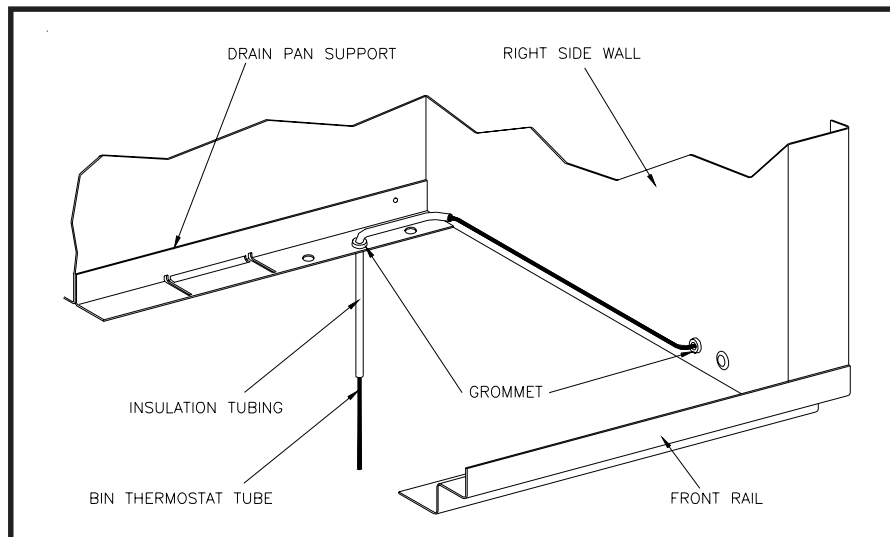

GT3XX Thermostat Installation

GT5XX: Install the insulated bin thermostat tube down the right-front corner of the frame, along the front rail, under the right side drain pan flange, through the bulb tube holder and down into the bin. Be careful not to kink the cap tube when bending it. Form it against your finger or other round object.

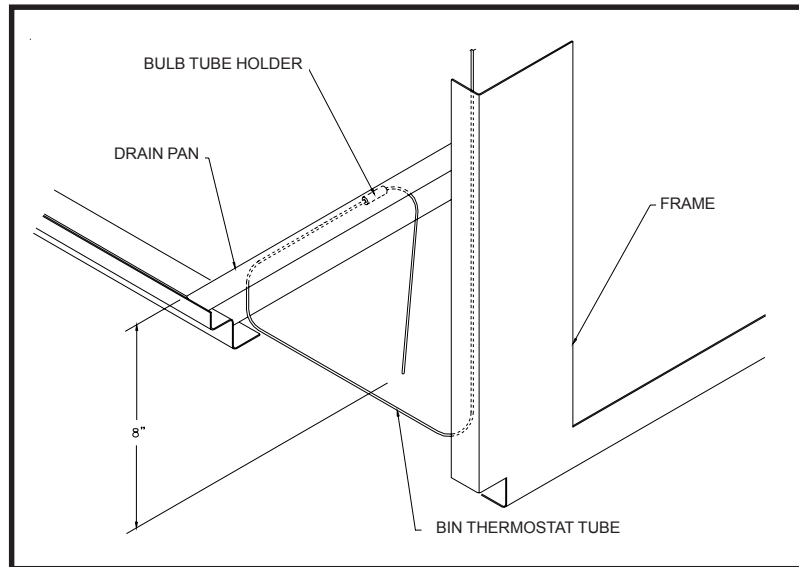

GT5XX Installation

START-UP INSTRUCTIONS

Consult the troubleshooting guide if variations from the following description of operation are noticed:

Mode Selector Switch:

1. Move the "ICE-OFF-WASH" switch to the center (OFF) position.

Power and Water Supply:

2. Be sure that condenser liquid ("W" models) or refrigerant lines and condenser (Remote models) are ready for use before turning power on. Turn on supply water and power. Check for leaks in water/liquid supply connections.

NOTE, "R" MODELS ONLY: The compressor will start immediately when power is applied, **regardless of the "ICE-OFF-WASH" switch position**, if the low-side pressure is at or above the pump-down controller cut-in setting. Be sure that the compressor stops when the low-side pressure is between 5 and 15 psig.

Prime the Pump:

3. Be sure that pump hoses are connected, then put about one pint of clean tap water into the circulation system to lubricate the pump seal.

Start the Ice Maker:

4. Move the “ICE-OFF-WASH” switch to the “WASH” position and observe the water fill cycle and the pump running. If all water plate distributor holes do not produce full streams and the appearance of air is evident in the tube, pinch the plastic tube connected to the water solenoid valve outlet while water is running until the streams are full all the way across the distributor tube. Water fill is complete when the water in the liquid level control tube reaches the high-level probe. At this time observe that the water shuts off and that there are no water leaks (dripping into the drain pan).



Open the Water Plate:

5. Pull the right end of the water plate down, stretching the springs until the pump stops, and hold the water plate down until the pump does not restart when the water plate is released. The water plate will open fully to dump the batch of water previously taken in, then close immediately. The water plate should stop when it is fully closed, and the water fill cycle will repeat.

Start Ice Production

6. After the water fill is complete move the “ICE-OFF-WASH” switch to the left “ICE” position and observe that the compressor (and fan in “A” models) starts, and the water pump continues to run. The refrigeration system operation should be checked during the first few cycles, and any adjustments should be made at this time. Initial ice making cycles may exhibit supercooling of the circulating water so that ice crystals form in the circulating water (“slush”), possibly stopping the flow momentarily. If water goes over the control stream dam when circulation resumes after three (3) cycles, close expansion 1/4 turn and cycle for a minimum of three (3) cycles, if the problem persists repeat the previous step.
7. Test the bin thermostat(s) by holding some ice against the bin thermostat tube(s). If necessary, adjust the thermostat(s) sensitivity towards + so that the ice maker(s) shut off within 30 seconds after ice contacts the thermostat tube(s).



Clean Up:

- Discard ice from start-up cycles, then clean and sanitize the bin following the instructions provided with the bin.

Registration and Instructions:

- Complete and mail the Registration Certificate and leave this manual with the owner/user. Emphasize the “CAUTION: RISK OF PERSONAL INJURY...” NOTICE ON THE COVER OF THIS DOCUMENT.
- Reinstall the cabinet panels even if the ice maker will not be operated immediately.

WATER LEVELS, CYCLE TIMES, AND REFRIGERANT CHARGES

	MODEL NUMBER			
	GT35X		GT55X	
	K	C/HK	K	C/HK
Water fill level (Top of tank to level in control tube, inches)	3	2.63	3.63	2.75
Approximate cycle time, minutes	14	28	15.5	31/24
Approximate harvest weight, pounds	2	3.5	4	7.7/7.1

* Values are for Air-cooled model at 90°F air and 70°F water temperatures with ice maker adjusted to produce fully-formed ice. Greater ice capacity can be obtained by reducing the water fill level (lowering the high-level probe) to produce ice with larger dimples. A slight adjustment of the probe will result in a noticeable effect on dimple size. The control stream will not rise over the dam with lower water fill levels than indicated above.

TYPICAL REFRIGERANT OPERATING CONDITIONS

All pressures are psig

TIME	LOW-SIDE, R-404a	HIGH-SIDE		
		R-404a		
		W	A	R
Beginning of freeze cycle	Approx. 50	250*	**	200 Min. ****
Just before harvest	12 to 20	250*	***	200 Min. ****
Harvest cycle	70 to 150	Approx. 150	Approx. 150	150 Minimum

All pressures may vary with operating conditions and adjustments.

- * 104° F condensing temperature—adjustable with coolant regulator valve.
- ** High-side pressure at beginning of freeze cycle in “A” models is likely to be higher than pressures shown for “W” models.
- *** High-side pressure just before harvest in “A” models in cool ambients is likely to be lower than pressures shown for “W” models.
- **** See remote condenser charging requirements if lower than minimum shown.

Kold-Draft Ice Maker Installation Checklist

- Are the ice makers and bin level?
- Is there proper clearance around the machine for air circulation?
- Have all electrical, water and sewer connections been made?
- Has the supply voltage been tested with the ice maker on a dedicated, protected circuit?
- Is the machine installed where ambient air temperatures will range from 45 to 90F (7 to 32C)?
- Is the machine installed where incoming water temperatures will range from 45 to 90F (7 to 32C)?
- Does the water supply provide a minimum 20 psig dynamic to maximum 100 psig static pressure?
- Is there a separate drain line for the water cooled condenser?
- Are there separate drain lines for the ice maker and bin?
- Are the ice makers and bin drains vented?
- Is the bin thermostat run correctly, secured, tested and positioned in the bin at the right level?
- Is the gasket positioned between the perimeter of the ice maker and bin top?
- Are the electrical lines free from contact with refrigerant lines and moving parts?
- Are the drain pan and ice chute positioned properly and is the packing tape removed?
- Has the start up process been completed with good ice quality?
- Have you cleaned and sanitized the ice maker and bin?
- Is the mode selector switch set to the ice position?
- Are the cabinet panels secured?
- Has the owner been instructed regarding cleaning, maintenance and the high pressure reset button?
- Has the owner completed the registration card?
- Have you left the installation and operation manual?

Additional Remote Model Checklist

- Does the remote condenser fan operate properly?
- Are the refrigeration lines run so they don't form a trap, other than a service loop at the back of the ice maker, or sit in water? Is any excess tubing located indoors?
- Is the refrigeration discharge line, to the remote condenser, insulated?
- Is the system adequately charged considering ambient temperature, line length & condenser volume?

WIRING DIAGRAM KOLD DRAFT 'CLASSIC' ICE CUBE MAKER GT3XX SERIES

L1

L2 (N)

W (115 V/60 HZ)
BR (208-230 V/60 HZ)
BU (220-240 V/50 HZ)

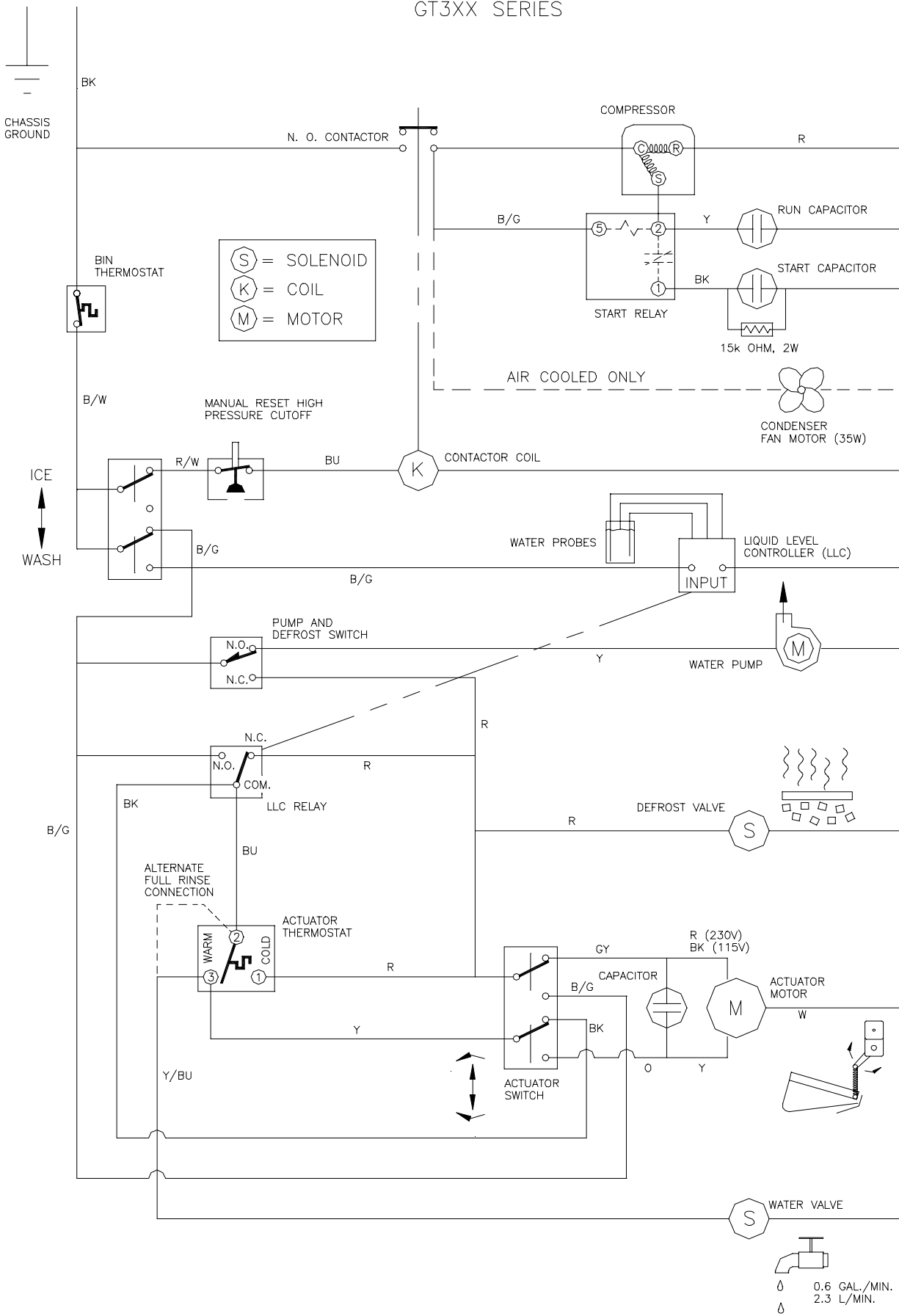

COLOR CODE	
BK	BLACK
B/G	BLACK/GREEN
B/W	BLACK/WHITE
BU	BLUE
GY	GRAY
O	ORANGE
PK	PINK
R	RED
R/W	RED/WHITE
W	WHITE
Y	YELLOW
Y/BU	YELLOW/BLUE

WIRING DIAGRAM
KOLD DRAFT 'CLASSIC' ICE CUBE MAKER
GT55X SERIES

COLOR CODE	
BK	BLACK
B/G	BLACK/GREEN
B/W	BLACK/WHITE
BU	BLUE
GY	GRAY
O	ORANGE
PK	PINK
R	RED
R/W	RED/WHITE
W	WHITE
Y	YELLOW
Y/BU	YELLOW/BLUE
Y/O	YELLOW/ORANGE

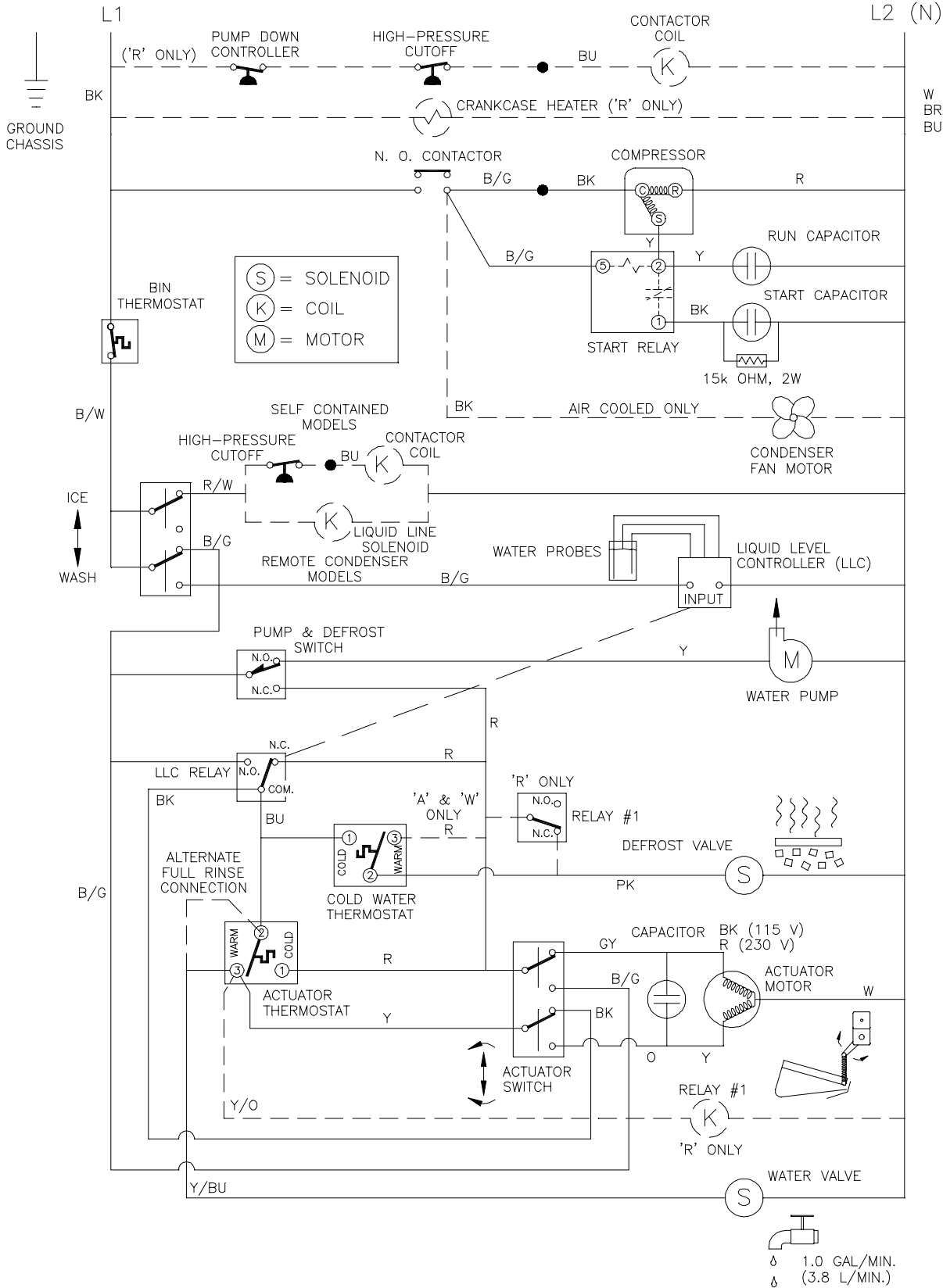

KOLD-DRAFT

101 Corporate Woods Parkway
Vernon Hills, IL 60061

USA

847-215-4500

800-726-8762

FAX: 847-541-1759

www.kold-draft.com

KOLD-DRAFT

an Ali Group Company



The Spirit of Excellence